

DESCRIPTION

The DJ-4114A is a four microphone/line input automatic mixing module. One or more DJ-4114A modules combined with a single DJ-4115A or DJ-4115A-1 Voice-Matic[®] Master approximates the gain, stability, and noise performance of a single microphone system for multiple microphone installations. The DJ-4131A Voice-Matic[®] linking module enables expansion to additional mainframes, multi-channel systems, and mix-minus systems.

DESIGN SYMBOL

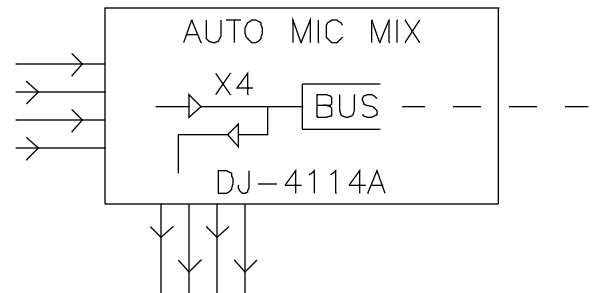

FEATURES

- Patented Dynamic Threshold Sensing (DTS) Technology
- Last Mic Hold
- Auxiliary Mix Bus for Combining Gated or Ungated Channel Inputs
- Removable Screw Clamp Style Input and Output Connectors
- Moveable Pin Jumper Selection of All Configuration Settings
- Four Balanced Microphone/Line Inputs Each With:
 - Studio Grade Bifilar Center-Tapped Transformer
 - Balanced Attenuator for Line Level Sources
 - Remote Level Control with 60dB Control Range (Bypassable)
 - Selectable 15 Volt Phantom Power
 - Remote Input Mute (-15dB or -30dB)
 - Remote Input Switch (-80dB)
 - Buffered Preamplifier Output, Pre/Post Gate Selectable
 - Selectable Input Gain (+20dB or +40dB)
 - Selectable 100 Hz High-Pass Filter
 - Open Collector Status Output
 - Selectable Channel Off Attenuation (-15dB or -30dB)
 - Automatic/Direct Mode Select Switch
 - Channel Status LED Indicator

FUNCTIONAL DIAGRAM

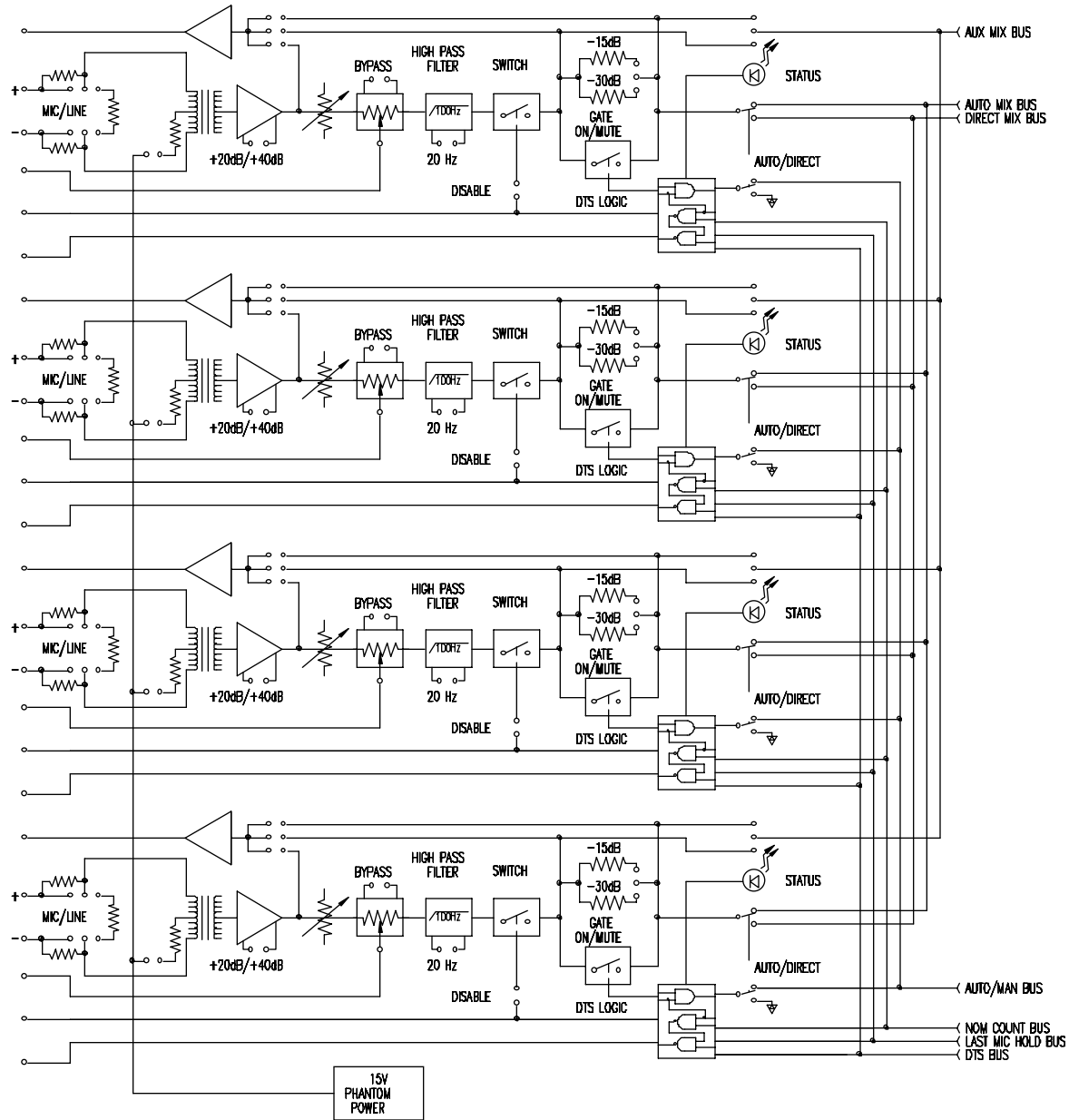

SPECIFICATIONS

GAIN IMPROVEMENT	+ 5.6dB (4 inputs), + 17.7dB (64 inputs)
BACKGROUND NOISE REDUCTION	+ 5.6dB (4 inputs), + 17.7dB (64 inputs)
CHANNEL OFF ATTENUATION	-30dB factory set, jumper selectable to -15dB
MICROPHONE/LINE INPUT	Transformer balanced and isolated
Recommended Source Impedance	< 600 Ω in MIC position/< 2k Ω in LINE position
Crosstalk Attenuation Between Channels	> 90dB @ 1 kHz
Connector	Three position pluggable terminal block
Standard Mic Setting (Preamp Gain @ 40dB, 150 Ω source)	
Input Impedance	1100 Ω
Maximum Input Level	-21dBV
Gain (measured at DJ-4115A output)	+ 54dB nominal; + 74dB maximum
Frequency Response	+ 0dB, -0.5dB, 20 Hz to 20 kHz, high-pass defeated
THD + Noise ... < 0.1% @ 0dBV output, 20 Hz - 20 kHz	
Equivalent Input Noise	< -127dBV
High Output Mic Setting (Preamp gain @ + 20dB, 150 Ω source)	
Input Impedance	1100 Ω
Maximum Input Level	-10dBV
Gain (measured at DJ-4115A output)	+ 33dB nominal; + 53dB maximum
Frequency Response	\pm 0.5dB, 20 Hz to 20 kHz, high-pass defeated
THD + Noise ... < 0.05% @ 0dBV output, 20 Hz - 20 kHz	
Line Level Setting (Mic/Line jumpers in Line position and Preamp gain @ + 20dB)	
Input Impedance	20.5k Ω
Maximum Input Level	+ 20dBV
Gain (measured at DJ-4115A output)	+ 3dB nominal; + 23dB maximum
Frequency Response	\pm 0.5dB, 20 Hz to 20 kHz, high-pass defeated
THD + Noise ... < 0.05% @ 0dBV output, 50 Hz - 20 kHz	
HIGH-PASS FILTER	
Rolloff	
6dB/octave @ 100 Hz, jumper selectable	
PREAMP OUTPUT	
Source	Pre/post gate or pre/post remote, jumper selectable
Gain, Standard Mic Setting	
Pre Level	+ 40dB
Pre Gate (Remote bypassed)	+ 50dB nominal; + 60dB maximum
Post Gate (Remote bypassed)	+ 50dB nominal; + 60dB maximum
Gain, High Output Mic Setting	
Pre Level	+ 20dB
Pre Gate (Remote bypassed)	+ 30dB nominal; + 40dB maximum
Post Gate (Remote bypassed)	+ 30dB nominal; + 40dB maximum
Gain, Line Level Setting	
Pre Level	-10dB
Pre Gate (Remote bypassed)	0dB nominal; + 10dB maximum
Post Gate (Remote bypassed)	0dB nominal; + 10dB maximum
Impedance	560 Ω for high impedance load, single ended
Maximum Output	+ 19 dBV, unloaded
PHANTOM POWER	+ 15 VDC @ 10 mA per channel
STATUS OUT	Open collector, 50 mA sink
Connector	9 pin female D-subminiature
REMOTE CONTROL	
Individual Preamplifier Gain	60dB range LED/LDR, 100k Ω ccw log taper potentiometer controls
Input Mute	-30dB (jumper selectable to -15dB), operate with open collector transistor logic or dry contact to ground
Individual Solid State On/Off	-80dB @ 1 kHz, operate with open collector transistor logic or dry contact to ground
Connector	9 pin female D-subminiature
CHANNEL ON INDICATION	LED, each input channel
CURRENT CONSUMPTION	
Remote Level Controls Disabled	50 mA maximum
Remote Level Controls Enabled	90 mA maximum
MODULE SPACE	One unit, 1.2 inches

OPERATION

The unique operating principal of the DJ-4114A Voice-Matic Microphone Mixer uses Dynamic Threshold Sensing (DTS) to differentiate between active and inactive microphones. DTS generates a threshold reference which starts at high levels and scans over an 80dB range to low levels. All microphone input channels are compared to the threshold reference simultaneously. When the DTS sensor determines the first channel that exceeds the threshold reference level, that channel is given "on" status. The microphone is rapidly turned "on" when activated, preventing upcutting of leading audio signals. Simultaneously the threshold reference is reset high and another scan is started. When a channel is given "on" status, an individual timing cycle is initiated, maintaining the channels "on" status for a preset period of time. On a repeated scan, the same or a different channel may exceed the threshold reference level, receive "on" status and have its timing cycle effectively updated without dropouts. Rather than turning an inactive microphone "off", it is attenuated by an internally preset -15dB or -30dB. A continuous count of the number of "on" microphones is used to adjust the master amplifier gain in the DJ-4115A series Voice-Matic Master. This is according to the rule of reducing gain by 3dB for each doubling of the number of simultaneously active microphones (Gain = 10 LOG NOM).

ARCHITECT'S SPECIFICATIONS

The automatic microphone system shall be modular in construction allowing indefinite expansion of inputs. The mixer shall provide automatic attenuation of inactive input channels. Each channel shall be gated either on or off (-15/-30dB selectable) automatically and shall not be gain modulated by other input channels except as necessary to maintain feedback margin through automatic master gain reduction when simultaneously active inputs occur. A smooth, automatic, 3dB master gain reduction for each doubling of simultaneously active channels is required. Channel activity shall be determined via dynamic threshold sensing circuitry. Static (fixed) threshold sensing shall not be acceptable. All inputs shall be transformer coupled. Microphone inputs shall each be capable of 15 volt phantom powering via jumper selection of the transformer center tap.

A buffered preamplifier output for each input channel shall be provided. The preamplifier output shall be jumper selectable to points pre level and remote switch functions, or to pre or post gate. All input channels shall be convertible from microphone to line level via jumper selection. Input channel status shall be displayed by individual LED's. An open collector status output for each input channel shall be provided. Each input channel shall be provided with individual on/off remote control capability. A remote dry contact or open collector transistor logic to ground shall activate the gate for muting each input channel. A jumper selectable switch shall provide 80dB of attenuation @ 1 kHz when activated via the remote muting circuitry. A last mic hold function shall be provided which shall maintain active status of the most recently utilized input channel during a period of inactivity. Each input channel shall have a 100 Hz high-pass filter that may be field bypassed with a jumper. Each input channel shall be switchable to automatic or direct (permanently on) mode by a front board edge switch. An auxiliary mix bus, programmed with either gated or ungated input signals via jumper selection, shall be provided. Individual remote control of input channel levels shall be provided. A 100kΩ ccw log taper remote DC control potentiometer shall provide a 60dB range of control. The automatic microphone mixer modules shall mount in and be powered by the IRP Model DJ-4100, DJ-4101, or DJ-4150 mainframe. The automatic microphone mixer modules shall be the IRP DJ-4114A Voice-Matic Microphone Mixer.

See DJ-4115A, DJ-4115A-1 and DJ-4131A for additional Voice-Matic Mixer architect specifications.

ORDERING INFORMATION

Specify: DJ-4114A Voice-Matic Microphone Input Module