

DESCRIPTION

The DJ-4122-1 is a matrix mixer with four active balanced inputs and four active balanced outputs. Remote controlled solid-state cross-point switches select any or all inputs to any output. Eight independent preset configurations of input and output mixing are provided by a DJ-4128-4 Remote Matrix Controller.

DESIGN SYMBOL

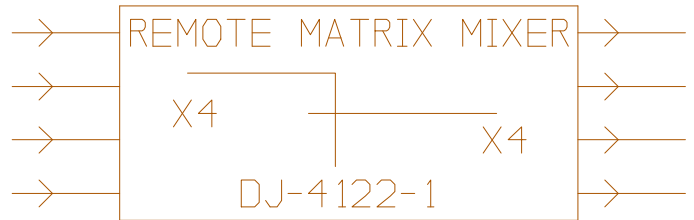

FEATURES

- Unity Gain
- Remote Control via DJ-4128-4
- Low crosstalk/feedthrough
- Ideal for Mix-Minus systems
- Clickless switching
- Five Year Limited Warranty

FUNCTIONAL DIAGRAM

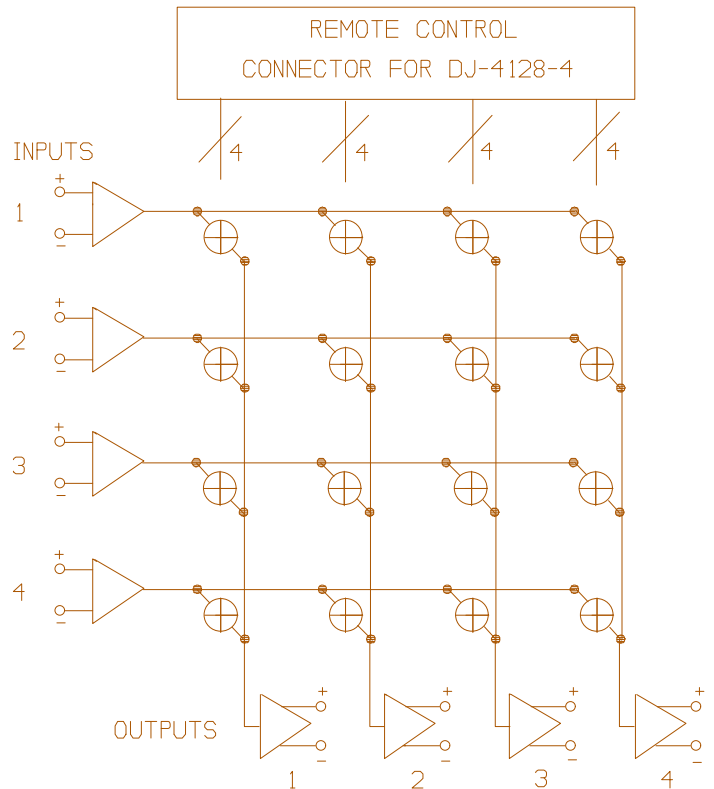

Note: Remote maintained contact closures to ground engage solid-state cross-point switches in matrix.

OPERATION

Remote controlled Matrix Mixers are ideal for any sound system where the signal routing regularly changes between two or more configurations. Conference rooms and hotel ballrooms with movable partition walls can use a remote controlled matrix mixer for an easy to operate room-combining system. In a large sports arena with multiple loudspeaker clusters the signal routing to the various clusters is often changed. Signal delays and other processing devices are often added or removed from the signal path (via patch panels) depending on the event in the arena. Remote controlled matrix mixers can eliminate patch panel changes and allow one-touch re-routing of the entire signal path configuration.

SPECIFICATIONS

LINE INPUT	Standard SYSTEM 41 active balanced
Impedance82k Ω balanced, 41k Ω unbalanced
Maximum Input	+ 19dBV
LINE OUTPUT	Standard SYSTEM 41 active balanced
Impedance	200 Ω for 600 Ω or greater load
Maximum Output	+ 19dBV, unloaded
GAIN	0dB (unity)
FREQUENCY RESPONSE*	+ 0dB, -0.5dB
THD*	Less than 0.02% @ 0dBV output
EQUIVALENT INPUT NOISE*	Less than -90dBV
CROSSTALK/FEEDTHROUGH	Less than -70dB @ 1 kHz
CURRENT CONSUMPTION	40 mA
MODULE SPACE	One unit, 1.2 inches wide

* Measured over a 20 Hz - 20 kHz bandwidth

ARCHITECT'S SPECIFICATIONS

A remote controlled matrix mixer shall provide four active balanced inputs and four active balanced outputs. Each output shall be independently and remotely assignable to include a mix of any or all inputs. All switches shall be solid state and shall be activated by remote dry contact or open-collector logic connections to ground, as provided in the IRP model DJ-4128-4 Remote Matrix Controller. Audible clicks shall not occur when switch settings are changed. Gain shall be unity. Feedthrough of non selected inputs and crosstalk between outputs shall be attenuated by greater than 70dB at 1 kHz. Equivalent input noise shall be -90dBV or less, 20 Hz to 20 kHz. THD shall be less than 0.02% at 0dBV, 20 Hz to 20 kHz. The outputs shall be monitored by a signal present LED. The remote controlled matrix mixer shall be mounted in and powered by the IRP model DJ-4100, DJ-4101, or DJ-4150 mainframe. The remote controlled matrix mixer shall be the IRP model DJ-4122-1 Remote Controlled 4 x 4 Matrix Mixer.

ORDERING INFORMATION

Specify: Remote Controlled 4 x 4 Matrix Mixer DJ-4122-1