

DESCRIPTION

The DJ-4132-21 provides two independently delayed outputs selectable in 1.0 millisecond steps to 255 milliseconds maximum. Dynamic range exceeds 100dB, eliminating excessive residual noise. Frequency and power response extend to 20 kHz. The DJ-4132-21 is ideal for synchronizing main clusters and shadowed areas, and distributed reinforcement systems where intelligibility and naturalness are desired.

The DJ-4132-21 is used in reconfigurable sound systems, such as multi-purpose arenas, conference rooms, or hotel ballrooms. Unique delay settings are remotely recalled to provide proper acoustic compensation for various microphone, stage, or headtable locations, etc., relative to distinct loudspeaker positions.

The DJ-4132-21 allows four different delay settings to be stored in non-volatile memory for each output. Maintained remote contact closures independently select one of the four pre-set delays for each output. For digital output expansion or digital delay extension see DJ-4133/4134. For precision microsecond resolution see DJ-4135/4136/4139.

DESIGN SYMBOL

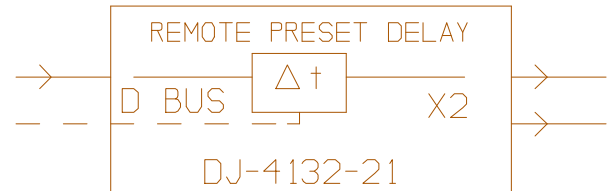

FEATURES

- § 1 input - 2 delayed outputs
- § Greater than 100dB dynamic range
- § 20 kHz bandwidth
- § Input and output level controls
- § 4 delay presets for each output

- § Adjustable in 1.0 ms steps to 255 ms
- § Digital output and delay expansion (no noise accumulation)
- § Clip and signal present LEDs
- § Active balanced input and outputs
- § Independent remote selection of delay presets

FUNCTIONAL DIAGRAM

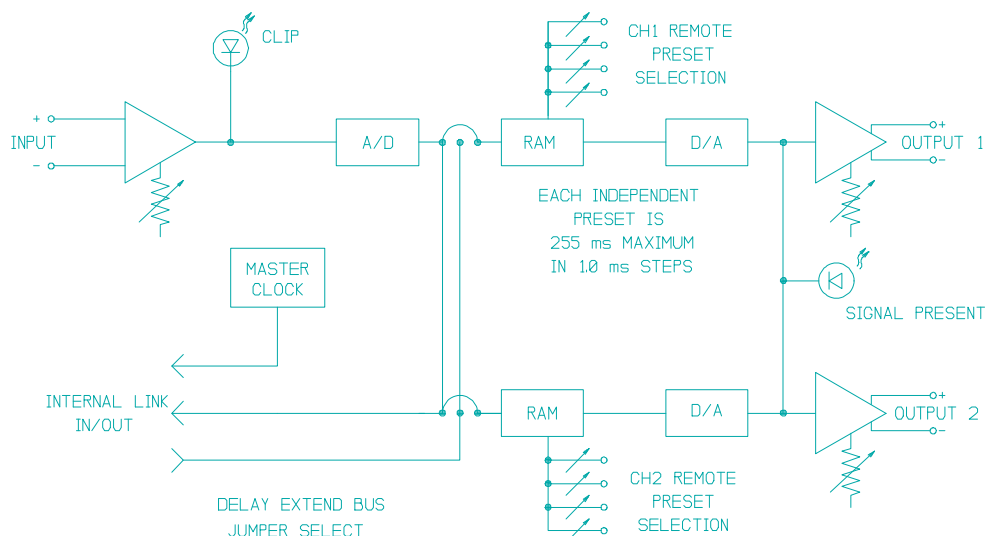

OPERATION

The DJ-4132-21 converts the audio input into a single bit digital stream at 2.048 MHz. The digital signal is stored in dynamic random access memory (DRAM) for the delay required. The delayed digital signal is then reconverted for the audio output. To provide the 100dB dynamic range necessary for quality sound systems to be free from residual noise, a proprietary audio/digital/audio converter was developed. In addition to using a high (2.048 MHz) sample rate which eliminates the need for sharp input and output band-limiting filters, the DJ-4132-21 internally adjusts the coarseness of the digital approximation to the audio input signal. Using this method, lower audio levels are digitized with finer digital steps thereby improving the S/N (Signal/Noise) ratio at lower signal levels. This results in a wider signal dynamic range for quality audio delay and reduction in the no signal residual noise. Digital bit stream linking of modules provides for expanding outputs or extending the delay settings without accumulating A/D/A conversion noise.

SPECIFICATIONS

LINE INPUT	Standard System 41 active balanced
Impedance	82kS balanced, 41kS unbalanced
Maximum Input	+ 19dBV
LINE OUTPUTS	Standard System 41 active balanced
Impedance	200S for 600S or greater load
Maximum Output	+ 19dBV, unloaded
INPUT GAIN	Adjustable; 0dB nominal, + 10dB maximum
OUTPUT GAIN	Adjustable; attenuate only, 0dB maximum
OVERALL GAIN	0dB nominal, + 10dB maximum
FREQUENCY RESPONSE*	+ 0dB, -3dB
THD + NOISE*	0.1% @ 1 kHz/0dBV
NOISE*	Less than -83dBV, 0dB output atten.; -93dBV, -10dB output atten.
DYNAMIC RANGE*	Greater than 100dB
DELAY	Adjustable in 1.0 ms steps to 255 ms maximum
TRANSIT TIME	24Fs
STABILITY	0.01%
CURRENT CONSUMPTION	130 mA
MODULE SPACE	One Unit, 1.20 inches

* Measured over a 20 Hz - 20 kHz bandwidth

ARCHITECT'S SPECIFICATIONS

The Audio Signal Delay shall provide two outputs, independently selectable in 1.0 millisecond steps to 255 milliseconds maximum. Delay for each output shall be set via two 16 position switches, the first providing 15 one-millisecond steps and the second, 15 sixteen-millisecond steps. A digital link shall provide for expanding the number of outputs and/or extending the delay maximum, thereby preventing noise accumulation. Four independent delay settings shall be stored in non-volatile memory for each output. Memory shall be set and stored by rotary switch positions. Maintained remote contact closures shall independently select one of the four delay presets for each output. The remote closures shall be to a subminiature 9-pin D socket mounted on the rear panel. The input and outputs shall be active balanced with level controls provided. A red LED shall indicate onset of clipping. The output signal shall be monitored by a signal present green LED. Frequency response shall be 20 Hz to 20 kHz +0, -3dB. Noise shall be less than -83dBV measured with a 20 kHz unweighted filter. The Audio Signal Delay shall mount in and be powered by the IRP DJ-4100, DJ-4101, or DJ-4150 mainframe. The Audio Signal Delay with remote presets shall be the IRP Model DJ-4132-21.

ORDERING INFORMATION

Specify: DJ-4132-21 Audio Signal Delay, 1 input/2 output with remote presets.

This device complies with Part 15 of the FCC Rules. Operation is subject to the following two conditions: (1) This device may not cause harmful interference, and (2) This device must accept any interference received, including interference that may cause undesired operation