



Professional Sound Products

SYSTEM 41[®]

DJ-4100/DJ-4101 Mainframe

Installation Manual

MECHANICAL INSTALLATION

IRP **SYSTEM 41** mainframes are designed to mount in a standard EIA 19 inch equipment rack. The DJ-4100, DJ-4101 and DJ-4151 mainframes are 10.5 inches high and requires a minimum of 11 inches depth behind the panel. The DJ-4150 is 3.5 inches high and requires a minimum of 11 inches depth behind the panel.

The DJ-4100, DJ-4101 and DJ-4151 mainframes will accommodate up to fourteen single width modules, each being 1.2 inches wide. Note that some modules are 2.4 inches wide.

All **SYSTEM 41** modules are installed from the rear of the mainframe. The module's circuit board is captured by card guides along the top and bottom edges. To install the module, carefully align the module into the card guides, then push it forward into the mainframe until it will go no further. Tighten the captive fasteners located near the top and bottom edges of the rear panel.

The **SYSTEM 41** mainframe has a hinged front panel held closed by two captive fasteners. When the hinged front panel is closed, a user control panel is left exposed. The panel on the DJ-4100 mainframe has a power on/off switch, and an LED which illuminates when both positive and negative 24 VDC is being supplied to the power bus rails in the mainframe. The DJ-4101 also includes two balanced attenuators, a monitor display, and monitor amplifier. The attenuators are undedicated and may be wired to act as system level controls.

SYSTEM WIRING

Connection between modules is accomplished using twisted pair wiring. To interconnect two **SYSTEM 41** modules, use the terminals on the rear panel, observing the (+) and (-) polarity indicators. Since all **SYSTEM 41** modules are grounded internally, connection to the system ground need be made only when external equipment is used. Wiring saddles are provided near the top of the mainframe. Routing all interconnections up and through the wiring saddle simplifies module replacement.

SYSTEM 41 is designed to reduce the amount of problems normally encountered in interfacing external equipment. If equipment is located in the same cabinet, either two-conductor shielded cable or a twisted pair will suffice. For longer runs, two-conductor shielded cable is recommended.

SYSTEM 41 uses balanced inputs and outputs throughout. This greatly simplifies connection to either single-ended or balanced equipment. Balanced lines will accommodate either balanced or unbalanced equipment. Wiring for the four basic cases is shown on the next page.

WIRING FOR FOUR BASIC CASES

CASE 1: Balanced output to balanced input

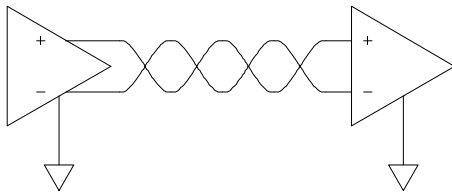

Twisted pair

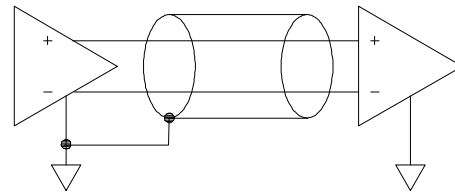

Two-conductor shielded cable

CASE 2: Unbalanced output to balanced input

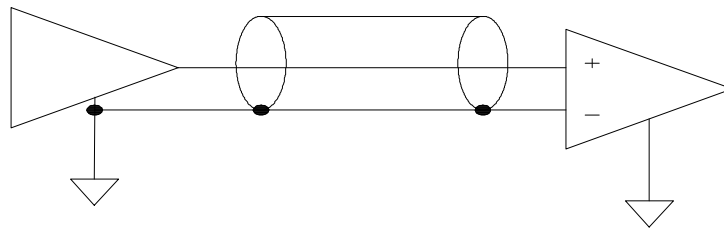

CASE 3: Balanced output to unbalanced input

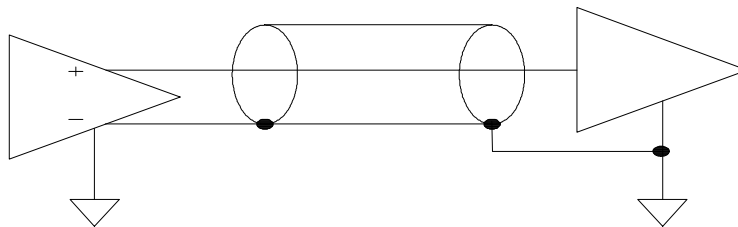

CASE 4: Unbalanced output to unbalanced input

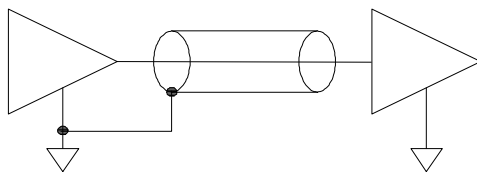

If units have their circuit grounds connected together

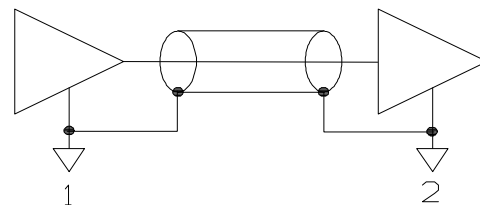

If units do not have their circuit grounds connected together (e.g. separate equipment racks)

POWER SUPPLY

The power supply delivers unregulated ± 24 VDC to all modules. The modules each have ± 15 V regulators to power their circuitry. The rugged power supply is built to provide exceptional reliability and freedom from mains-related problems. High quality components are used throughout, including a shielded toroidal power transformer, an effective EMI filter, and premium-grade electrolytic filter capacitors.

117 VAC, 60 Hz and 234 VAC, 50 Hz power versions are supplied.

If configured for 117V nominal operation, the unit is rated for operation between 105 and 130 VAC. If configured for 234V, the unit is rated from 210 to 260 VAC. Both versions use a 1.25 amp slow-blow fuse. The AC power fuse is located within the IEC connector for AC power on the rear panel.

The low voltage section of the power supply is a center-tapped bridge configuration and delivers a nominal ± 24 VDC at 1.2 amp (1.0 amp on DJ-4101) maximum to the modules. As this supply is unregulated, the voltage will drop with increased load. The unloaded voltage is typically ± 26 VDC; when delivering the maximum load current, the voltage is typically ± 22 VDC.

The power supply is more than sufficient to power most configurations. However, it is recommended that the total current requirement be determined when using a large number of single width modules or when using custom circuitry in the DJ-4124 and DJ-4125 modules. Ensure that the total load current does not exceed the power supply capacity of the mainframe (± 1.0 amp for the DJ-4101 or ± 1.2 amp for the DJ-4100). The current drain for each module is listed on its data sheet.

The ± 24 VDC fuses are located near the top on the rear panel of the unit. The positive and negative supplies are fused separately. Both fuses are 1.6 amp fast-acting.

ENVIRONMENT

The unit should be installed in a location where the temperature is maintained between 0° - 45° C (32° - 113° F) and the humidity is less than 95%, non-condensing. Although the mainframe provides exceptional shielding from electromagnetic fields, the unit should not be installed near strong sources of these fields.

MONITOR CIRCUITRY DJ-4101

The monitor section of the DJ-4101 is composed of two main elements: A peak-responding LED bar graph display and a three watt amplifier to drive a loudspeaker, headphones, or ancillary equipment. The monitor includes a switch to select one of two inputs.

The monitor is useful in the adjustment of the system as well as in troubleshooting. The display allows for accurate level measurements throughout the system, while the amplifier may be used to monitor the quality of the signal or even to provide sound reinforcement to a small room.

The level display is a ten-segment LED bar graph with a range of -25 dBV to $+20$ dBV; each segment corresponds to 5dB. The level indicator measures the input level. The indicated level is independent of the monitor amplifier level control. The inputs to the monitor are active balanced.

The monitor amplifier is driven from the same signal measured by the level display. The output is transformer isolated and may drive loads down to 4Ω . For loads between 4Ω and 8Ω use the 4Ω tap location on the rear panel; loads greater than 8Ω should use the 8Ω tap. The amplifier is not recommended for use with loads less than 4Ω . A headphone output is provided on the front panel and is suitable for driving either low or high impedance headphones. Either stereo or mono headphones may be used. A switch located on the front panel disables the rear panel monitor power amplifier output. An LED indicates the onset of clipping in the monitor amplifier.

GAIN PROGRAMMING

Resistor Changes

Many modules have input and output amplifiers whose gain may be modified by adding or changing the value of a single resistor (Gain Programming Resistor).

Each data sheet illustrates the location of these resistors which are highlighted on the board by large solder pads, or by PC board legend designations.

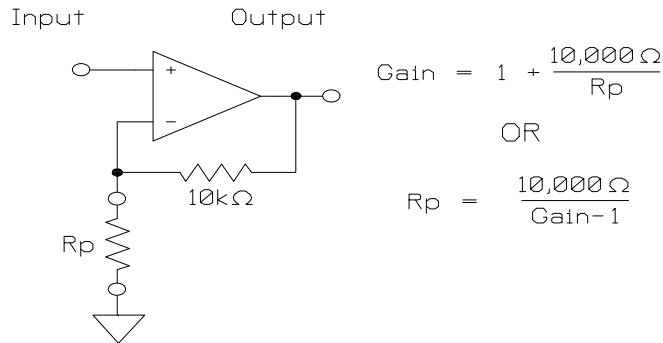

For good amplifier performance, R_p should not be less than 330Ω. R_p may be removed for unity gain. The above equation is typical for most modules which use a 10kΩ feedback resistor, but doesn't apply in all circumstances. Refer to the gain programming section on each module's set up instructions for the correct equation.

DOCUMENTATION

Write-On Panels

A number of documentation aids are supplied with each **SYSTEM 41** module. Write-on panels supplied with the modules provide documentation at the installation site. Each panel represents the controls and indicators unique to its respective module. The installer may indicate the position of each control on the panel. Space is also provided to describe the functions of each control. These panels may be installed in the unit on the hinged front panel. Mounting the panels in the cover allows the controls to remain accessible. The magnetic backing on the documentation panels also allows them to be hung adjacent to the module during set up. This temporary mounting is very useful when adjusting a module with many controls (such as the DJ-4117 $\frac{1}{3}$ Octave TEQ Transversal Equalizer).

Control Record Sheets

Control record sheets are supplied with each module. These sheets contain more detailed information than is found on the write-on panels, and may be installed in a binder kept by the installer or contractor. Information kept on this sheet comprises a permanent record of the original system configuration.

Design Symbols

In addition to the documentation specific to the modules themselves, design symbols are available in formats for AutoCad (with a .DWG file extension) or other Computer Aided Design programs which read standard format drawings (having a .DXF file extension).

REMOTE CONTROL OF LEVELS

Modules having remote level control capability as either a standard or optional feature are equipped with a subminiature D connector on the rear panel for control line connections. The appropriate set up/ documentation sheet provides a pin connection diagram. Two methods of control are used. Remote input level controls use an LED/LDR Opto-Isolator package. The DC current drive for the LED requires a 100k_ reverse taper log potentiometer (available as IRP P/N 105-0521) for correct audible performance of this circuit.

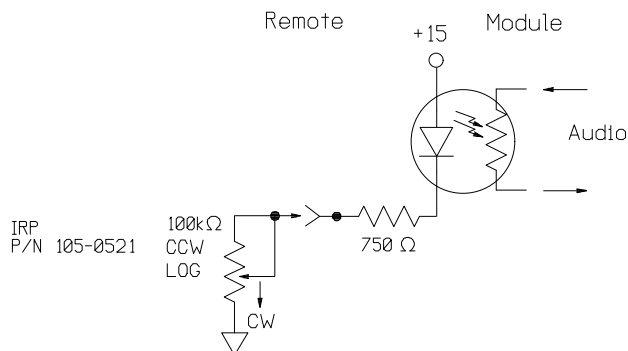

Remote output level controls use a single voltage controlled amplifier (VCA). Remote adjustment of the VCA is via a 10k_ linear potentiometer.

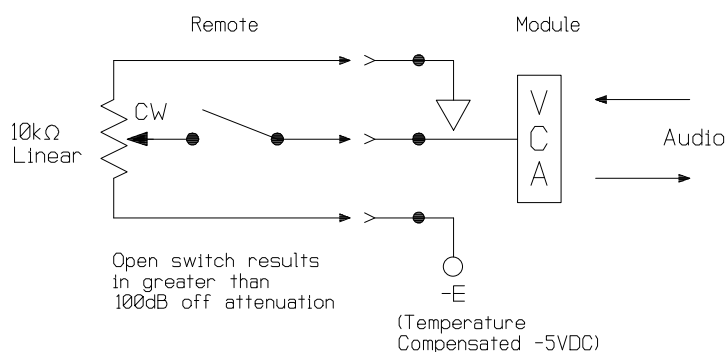

The remote switch is not required but allows turning the channel off (-100dB) without having to move the potentiometer setting. The attenuation relation of wiper input voltage referenced to ground is as follows:

- 10dB attenuation per Volt
- 0 Volt = FULL ON
- 1 Volt = 10dB attenuation
- 5 Volt = 50dB attenuation

(Again this is typical for most modules. Refer to appropriate set up sheet for more detailed information.)

REMOTE SWITCHING

Modules having remote switching capability as either a standard or optional feature are equipped with a 9 Pin subminiature D connector on the rear panel to which control line connections are made. The appropriate set up/control record sheet provides a pin connection diagram.

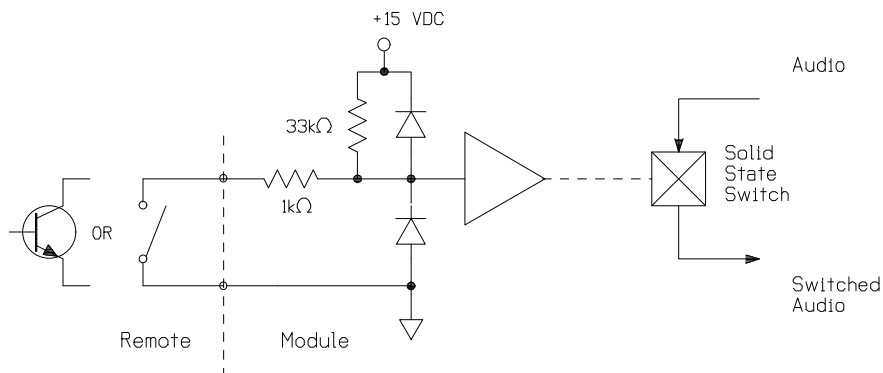

PHANTOM POWER

Modules having microphone inputs are equipped with a center-tap fed phantom power supply. A 1500Ω ¼W feed resistor has been installed on all microphone inputs. Each data sheet illustrates the location of this resistor which is highlighted on the board by large solder pads or legend marking. Remove the phantom power feed resistor, or move the appropriate phantom pin jumpers, whenever a dynamic microphone or a line level input is used.

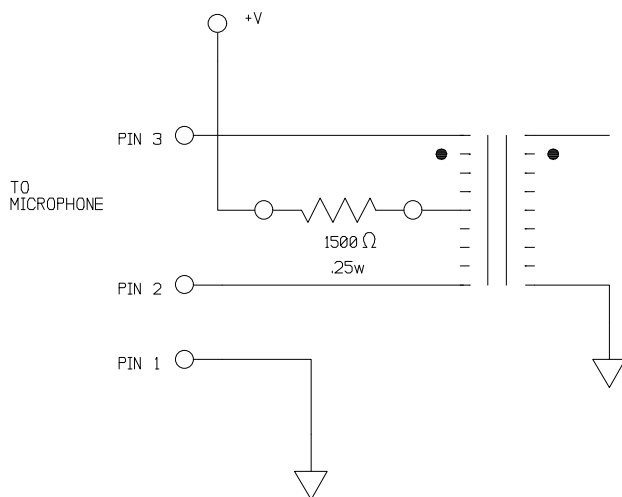

Note: Some powered microphones which draw higher current may require lowering the value of the 1500Ω feed resistor to maintain sufficient voltage at the microphone.

TROUBLESHOOTING

Power

Failure of the front panel power LED to light may indicate blowing of the 117/234 VAC rear panel fuse for AC power, or either rear panel ± 24 VDC fuses. If fuses continue to blow, all modules should be removed and systematically inserted until the faulty module is discovered.

Total current capacity of the power supply should not exceed 1.2 amp (for the DJ-4100) or 1.0 amp (for the DJ-4101) at ± 24 VDC. Systems with many single width modules or with custom modules may exceed the current limit.

Signal Tracing

All modules have a signal present LED on the module output. If a module has multiple outputs, the LED monitors the signals driving all outputs of the module. The brightness of the LED varies with signal strength to give an estimate of the output level of one module compared to the output levels of other modules in the system. Modules with many outputs (i.e. DJ-4118) will typically have brighter LED activity than those with only a single output.

Level Setting

All level controls have the appropriate normal set point marked on the documentation panel. If controls are at wide variance from these normal settings, system headroom or noise may suffer. Careful level measurements at each module's output should reveal if there is poor gain distribution. On a DJ-4101, the ten LEDs in the peak level display monitor may be used to measure levels at the input and output terminals of all modules. Any gain changes via changes in gain programming resistors should be documented in the Control Record section of the module's Set Up Procedure.

Hum and Noise

Turn level controls of unused inputs fully counter-clockwise. Unused inputs may be shorted (+) to (-) as desired.

All wiring should be by twisted pair or shielded cable between modules, and from modules to auxiliary equipment.

Follow wiring instructions in System Wiring section of this manual.

The circuit ground and chassis (safety) ground of the system should be tied together at only a single point as a MASTER-GROUND mainframe. The circuit ground terminals of all the equipment and additional mainframes in the system should be individually wired to a single point, in a STAR-GROUNDING connection to the MASTER-GROUND mainframe. Circuit ground to chassis ground connections should be removed in expansion mainframes.

Equipment located at a different power ground point (i.e. remotely located) should be isolated by transformers, either input, output, or both.

FIVE YEAR LIMITED WARRANTY

IRP warrants to the original purchaser each product manufactured by it to be free from defect in material and workmanship for a period of five years from date of sale to original purchaser, and agrees to remedy any such defect, or to furnish a new part in exchange for any part of any product of its manufacture which, under normal installation, use and service, discloses such defect provided such part or product is returned by the original purchaser to the IRP factory within five years from the date of sale, with all transportation charges prepaid, and provided that IRP examination discloses that it is defective.

This warranty does not extend to any IRP product which has been subject to misuse, neglect, accident, incorrect wiring by others, improper installation, or to use in violation of instructions furnished by IRP, nor to products on which the serial or identifying numbers have been removed, defaced or changed, nor to accessories used therewith not of IRP manufacture.

IRP's obligation under this warranty as to any products or parts approved by IRP for remedy or exchange is limited, at its option, to replacing such products or parts in kind without charge to the original purchaser, or to crediting the original purchaser with the purchase price of the returned defective products.

This warranty is in lieu of all other warranties, express or implied, and no representative of IRP or any other person is authorized to assume for IRP any other liability in connection with the sales of its product.