

Refer to the back page for Control Record.

Refer to **SYSTEM 41 Installation Manual** for general instructions on module installation and wiring.

Refer to **DJ-4122-1 Data Sheet** for product specifications and functional diagram.

### OPERATIONAL DESCRIPTION

The DJ-4122-1 is a remote controlled matrix mixer with 4 inputs and 4 outputs. Maintained dry contact switch (or open-collector transistor logic) closures to ground activate sixteen solid-state crosspoint mixing switches. The solid-state switch logic inputs are internally pulled-up to +15V. These logic inputs are designed for crosspoint activation from parallel "OR" remote switch connections.

The DJ-4122-1 mates with a DJ-4128-4 Remote Matrix Controller. The DJ-4128-4 provides eight Preset PROGRAMS of mixing configurations for the DJ-4122-1. Each Preset is a unique combination of any, or all of the 16 matrix crosspoints. Any or all of the Preset PROGRAMS are engaged via the remote connector on the DJ-4128-4. Simultaneous activation of multiple PROGRAMS address up to 256 different combinations of matrix mixer configurations with a single DJ-4128-4 Remote Matrix Controller.

### INSTALLATION SET UP

1. Pre-program the Preset matrix mixer PROGRAMS on the DJ-4128-4 Remote Matrix Controller using the pin-jumpers provided. Refer to the **DJ-4128-4 Set Up Procedure** for the specific pin-jumper positions corresponding to INPUTS, OUTPUTS, PRESETS, and INPUT LOCK programming.
2. Connect the DJ-4122-1 to the DJ-4128-4 by using the ribbon cable supplied with the DJ-4128-4.
3. Carefully insert the DJ-4122-1 and Remote Matrix Controller modules into the System 41 mainframe, while keeping the ribbon cable connected.

- 
4. Wire the inputs and outputs to the DJ-4122-1 by the methods described in the **SYSTEM 41 Installation Manual**.
  5. Use the thumbwheel switch on the DJ-4128-4 to verify that all Preset matrix-mixer signal routing and mixing PROGRAMS operate correctly. If signal routing is incorrect, pull out the DJ-4128-4 from the mainframe to inspect the placement of the programming pin-jumpers. Modify the pin-jumper positions as required until the Preset PROGRAM routing is correct, then re-install the DJ-4128-4 to the mainframe.
  6. When all Preset PROGRAMS are operating correctly from the thumbwheel switch on the DJ-4128-4, set the thumbwheel switch to position 0 or to position 9. Connect the remote switches to the Remote Control connector on the DJ-4128-4. The wiring to this connector is detailed in the **DJ-4128-4 Set Up Procedure**.
  7. Verify the correct operation of the remote control switches. Should incorrect operation occur, check for any short and/or open circuit connections in the remote wiring, then correct the difficulty.
  8. To increase the number of independent Preset PROGRAMS beyond eight, use two or more DJ-4128-4 Remote Matrix Controller modules connected to the DJ-4122-1.



Note: Contact the factory before placing the order so that a special ribbon cable may be supplied with the necessary multiple connectors for all modules. Use the same procedure outlined in steps 1 through 7, referring to all the DJ-4128-4 modules together in each step. In step #5, where the Preset PROGRAMS are verified, leave the thumbwheel switch in position 0 or 9 for all DJ-4128-4 modules except the module whose PROGRAMS are being checked.

9. When multiple DJ-4122-1 modules are being controlled by one or more DJ-4128-4 modules, again follow steps 1 through 7 (contact the factory for special cables). Every DJ-4122-1 module connected to a common Remote Matrix Controller will engage the same matrix crosspoint switches for all Preset PROGRAMS. This particular configuration is often used with two DJ-4122-1 modules controlled in tandem, i.e. for remote stereo source selection and routing (with one DJ-4122-1 each for the left and right channels respectively).
10. It is permissible to remotely switch the individual crosspoints directly on the DJ-4122-1. This technique is sometimes used when every one of the 16 crosspoints needs to be addressed independently. To wire the switches directly to the DJ-4122-1, it will be necessary to procure a ribbon cable female connector (34 conductor - dual row - 0.100 inch centers). The switch ground will connect to one of the circuit-common screw terminals on the mainframe. A maintained closure to ground engages each independent crosspoint. See the connector pin-outs on the following page.

## J2 CONNECTION TABLE

PIN	FUNCTION	PIN	FUNCTION
1	NO CONNECTION	18	+ 15VDC
2	INPUT 1 TO OUTPUT 1	19	NO CONNECTION
3	NO CONNECTION	20	INPUT 1 TO OUTPUT 4
4	INPUT 2 TO OUTPUT 1	21	NO CONNECTION
5	NO CONNECTION	22	INPUT 2 TO OUTPUT 4
6	INPUT 3 TO OUTPUT 1	23	NO CONNECTION
7	NO CONNECTION	24	INPUT 3 TO OUTPUT 4
8	INPUT 4 TO OUTPUT 1	25	NO CONNECTION
9	INPUT 4 TO OUTPUT 2	26	INPUT 4 TO OUTPUT 4
10	NO CONNECTION	27	INPUT 4 TO OUTPUT 3
11	INPUT 3 TO OUTPUT 2	28	NO CONNECTION
12	NO CONNECTION	29	INPUT 3 TO OUTPUT 3
13	INPUT 2 TO OUTPUT 2	30	NO CONNECTION
14	NO CONNECTION	31	INPUT 2 TO OUTPUT 3
15	INPUT 1 TO OUTPUT 2	32	NO CONNECTION
16	NO CONNECTION	33	INPUT 1 TO OUTPUT 3
17	+ 15VDC	34	NO CONNECTION

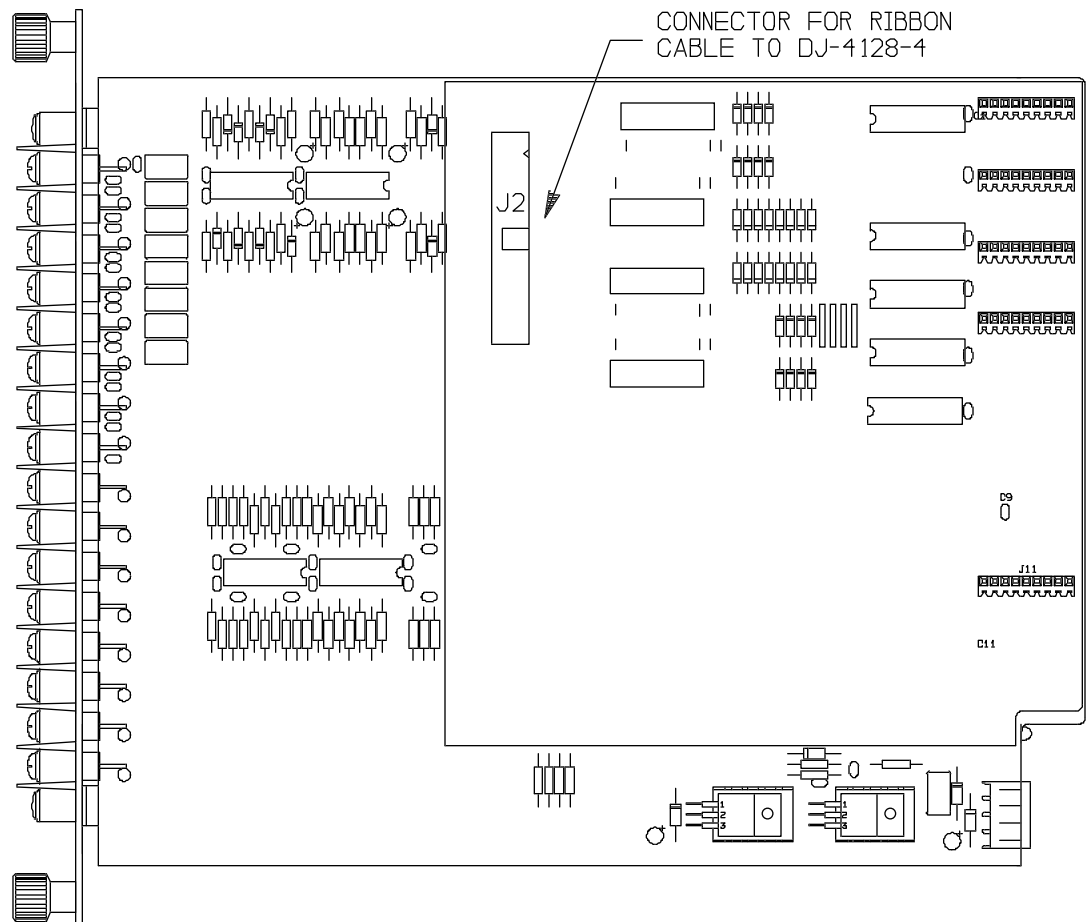
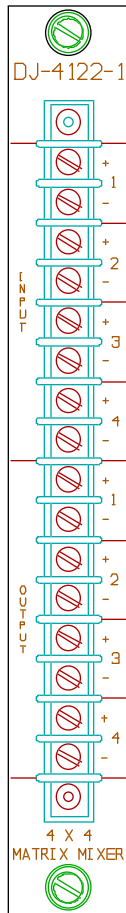

**REAR PANEL**

**MODULE DETAIL**

# Control Record

DJ-4122-1

REMOTE CONTROLLED

4 x 4 MATRIX MIXER

Record all input and output connections to and from the DJ-4122-1 on the Documentation Panel pictorial to the right. This should match the Documentation Panel in the mainframe.

OUTPUT/INPUT

	1	2	3	4
1 ON				
1 OFF				
2 ON				
2 OFF				
3 ON				
3 OFF				
4 ON				
4 OFF				

DJ-4122  
4 X 4  
MATRIX MIXER

SIG. ○

Mainframe # \_\_\_\_\_

Module Position # \_\_\_\_\_

Contractor \_\_\_\_\_

Installer \_\_\_\_\_

Job \_\_\_\_\_

Date \_\_\_\_\_