

Refer to back page for Control Record.

Refer to **SYSTEM 41 Installation Manual** for general instructions on module installation and wiring.

Refer to **DJ-4132-2 Data Sheet** for product specifications and functional diagram.

LEVEL CONTROLS

1. Set INPUT and OUTPUT level controls to "N" (Normal). The INPUT control should be mid-range and the OUTPUT control should be full clockwise. Gain will be unity (0dB) input to output.
2. Input sensitivity may be increased by clockwise rotation of INPUT control, with a maximum of 10dB gain. If the red CLIP LED flashes, reduce input sensitivity.
3. Rotate the OUTPUT control counterclockwise to reduce output level as required. Note: Best signal quality results when input clipping occurs simultaneously with maximum signal level of the sound system. Full dynamic range of the DJ-4132-2 is then utilized.

DELAY CONTROLS

1. The delay is set in COARSE (16 millisecond) and FINE (1 millisecond) increments. Total delay is the sum of these two settings. Refer to the table below to determine the preset values required to achieve the desired delay.
2. Adjust the COARSE and FINE controls to the delay value required.
3. Record control settings in the Control Record section, and on the documentation panel.

COARSE		FINE	
SETTING	INCREMENT	SETTING	INCREMENT
0	0ms	0	0ms
1	16	1	1
2	32	2	2
3	48	3	3
4	64	4	4
5	80	5	5
6	96	6	6
7	112	7	7
8	128	8	8
9	144	9	9
A	160	A	10
B	176	B	11
C	192	C	12
D	208	D	13
E	224	E	14
F	240	F	15

INPUT GAIN PROGRAMMING

The DJ-4132-2 module comes pre-programmed from the factory to have unity gain with the INPUT control in the Normal position (50% rotation) and the OUTPUT controls at full clockwise rotation. Full clockwise rotation of the INPUT control increases the input sensitivity by 10dB. Input sensitivity may be modified on the DJ-4132-2 by replacing the factory supplied resistor. The table below shows the acceptable resistor values to alter the "Normal" gain setting.

GAIN PROGRAMMING

GAIN PROGRAMMING RESISTOR	NOMINAL GAIN (dB)	MAXIMUM GAIN (dB)
NONE	-10	0
12k Σ	-5	5
4.7k Σ *	0	10
2.2k Σ	5	15
1k Σ	10	20

* Denotes factory supplied value



Caution: Always reduce the output level to all corresponding power amplifiers when adjusting the delay values during setup. Whenever delay values are changed, existing information in the digital bit-stream must pass through the Digital-to-Analog converter before any new delay value is correctly synchronized. Unsynchronized (old) digital information can create unpleasant, unpredictable output noise.

MODULE DETAIL

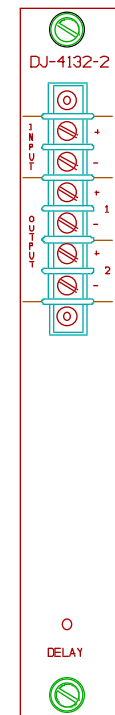
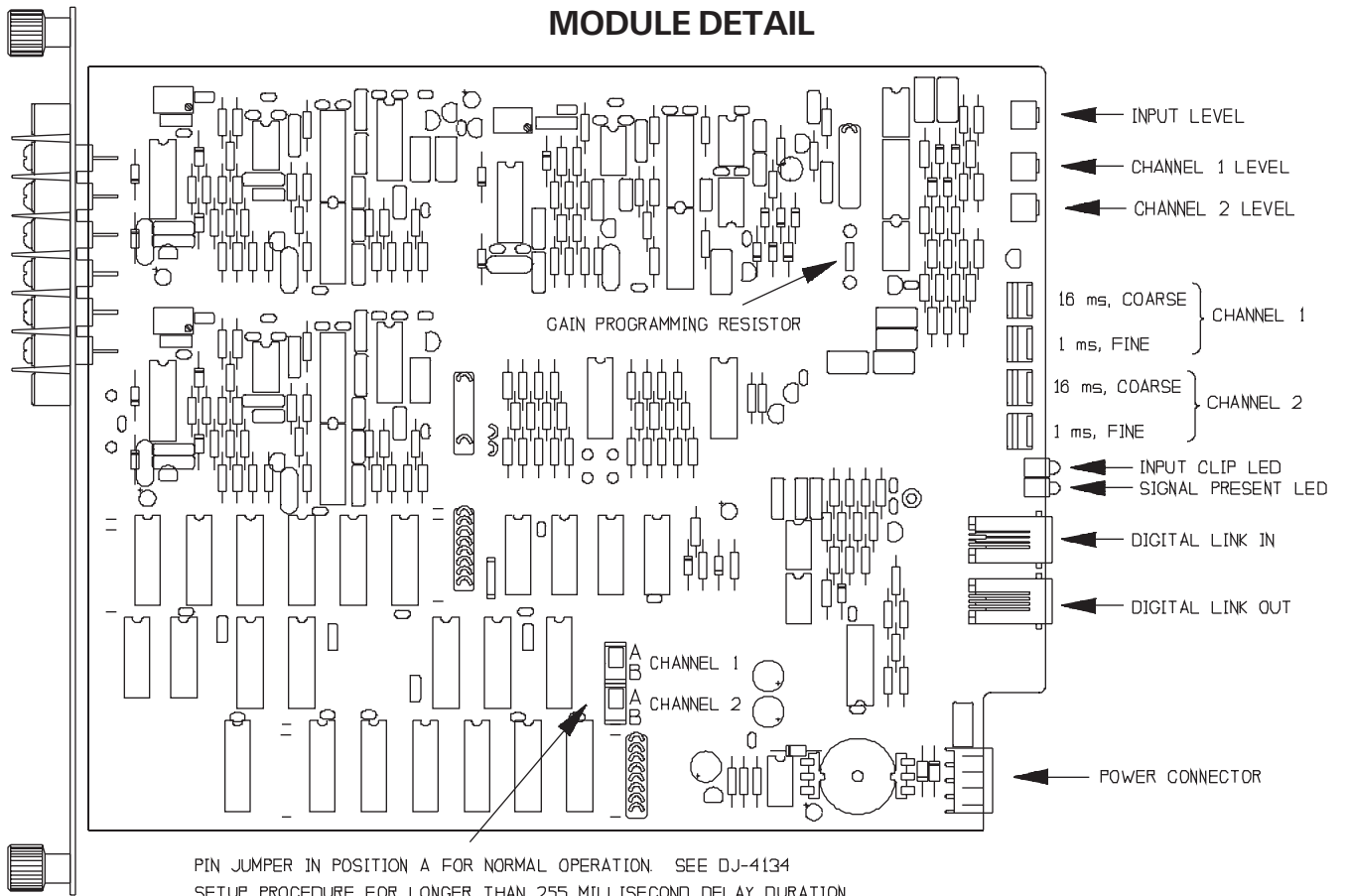

REAR PANEL

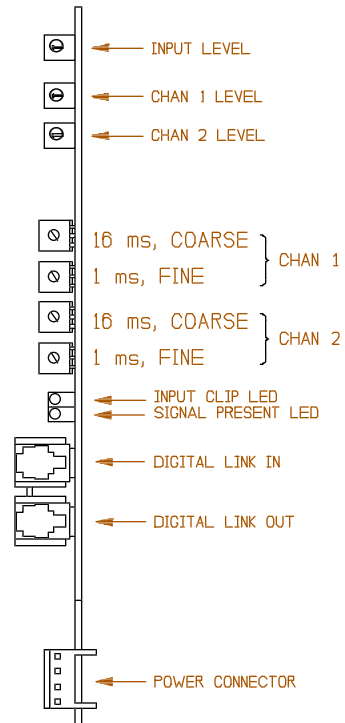

FRONT EDGE CONTROLS

Control Record

DJ-4132-2

AUDIO SIGNAL DELAY

Record all control settings on the Documentation Panel pictorial to the right. This should match the Documentation Panel in the mainframe.

Delay Setting	COARSE	FINE	TOTAL
OUTPUT 1			
OUTPUT 2			

INPUT N

OUTPUT 1 N

OUTPUT 2 N

DELAY SETTINGS
milliseconds

OUT 1 16

TOTAL 1

OUT 2 16

TOTAL 1

CLIP

SIG.

LINK IN

LINK OUT

DJ-4132-2
DELAY

Mainframe # _____

Module Position # _____

Contractor _____

Installer _____

Job _____

Date _____